

THELCO CUTAWAY DRAWING OF WORTHINGTON® PUMP MODEL D-812
MECHANICAL SEAL COVER VERSION. THIS IS THE "OLD D-812"

PUMP SIZES;

1-1/2 X 1 X 6	Frm-1
2 X 1 X 6	Frm-1
2 X 1 X 8	Frm-1
2-1/2X1-1/2X5	Frm-1
2-1/2 X1-1/2X6	Frm-1
2-1/2X1-1/2 X8	Frm-1
" "	Frm-2
2-1/2X2-1/2X4	Frm-1
3 X 2 X 5	Frm-1
2 X 1 X 8	Frm-1
3 X 2 X 6	Frm-1
" "	Frm-2
3 X 2 X 8	Frm-1
" "	Frm-2

Note;
Frm-1 Coupling end shaft dia is 7/8"
Frm-2 Coupling end shaft dia is 1"

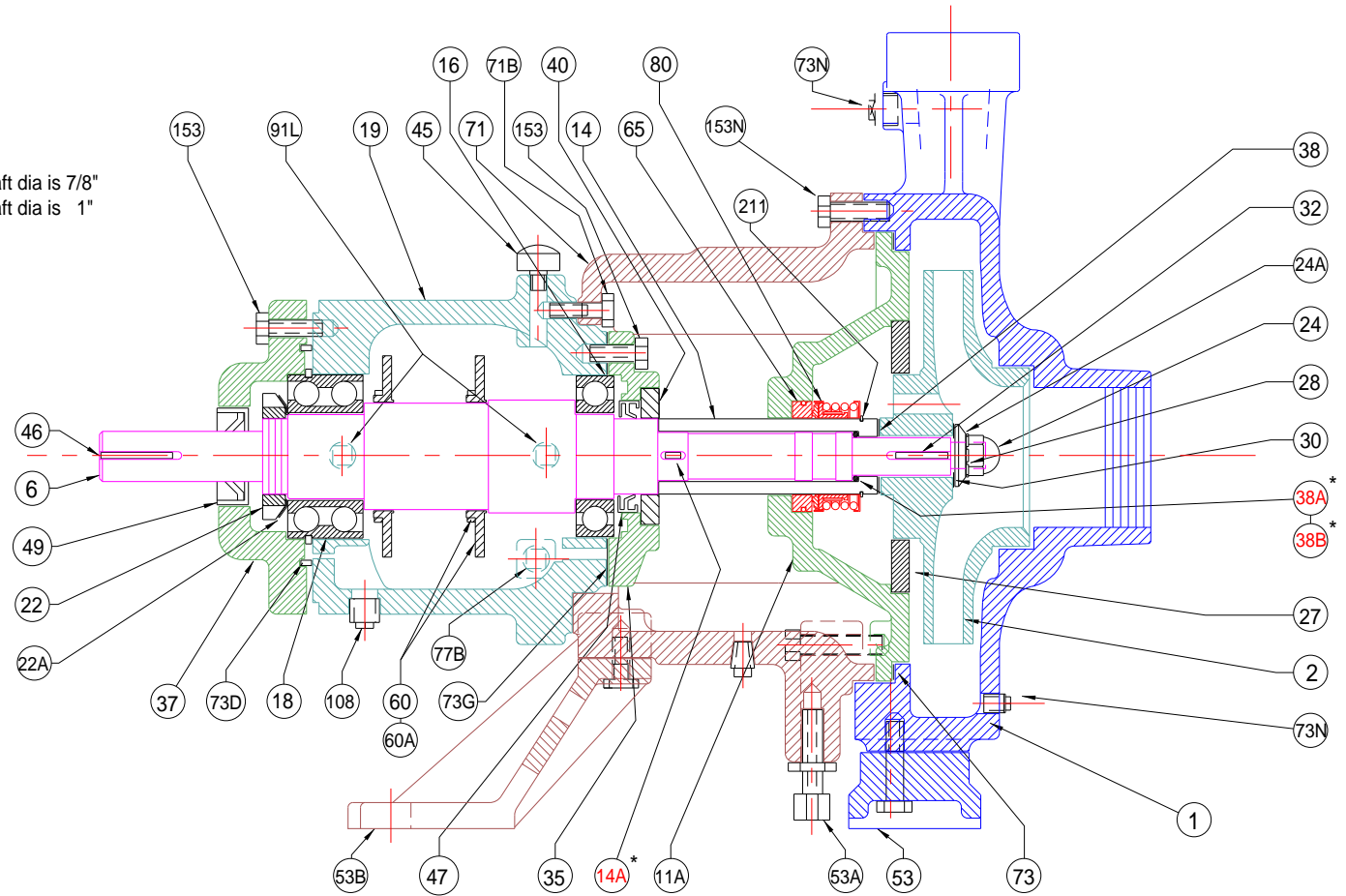
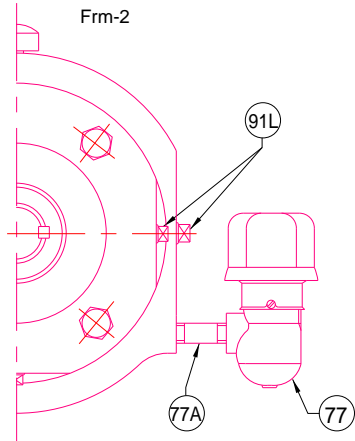

© Any reproduction must include this copyright notice.

WORTHINGTON® is a registered trademark of Ingersoll-Dresser Pump Company. Thelco is not affiliated with WORTHINGTON® or Ingersoll-Dresser Pump Company

REFERENCE NUMBERS

1	CASING	27	RING, ADAPTER COVER	47	LIP SEAL, LINE BEARING	73G	GASKET, LINE BEARING COVER
2	IMPELLER	28	GASKET, IMPELLER NUT	49	LIP SEAL, THRUST BEARING	73N	PIPE PLUG, CASING
6	SHAFT	30	GASKET, IMPELLER LOCK WASHER	53	FOOT, CASING	77	CONSTANT LEVEL OILER
11	A MECHANICAL SEAL COVER	32	KEY, IMPELLER	53A	ADAPTER SUPPORT, INBOARD	77A	NIPPLE, OILER
14	SLEEVE, SHAFT	35	COVER, LINE BEARING	53B	ADAPTER SUPPORT	77B	PIPE PLUG, GREASE LUBE PUMPS
14A	KEY, SLEEVE (FRM-1 ONLY)*	37	COVER, THRUST BEARING	60	FLINGER, OIL	80	MECHANICAL SEAL ROTOR
16	LINE BEARING	38	GASKET, SLEEVE	60A	COLLAR, OIL FLINGER	91L	PIPE PLUG, OIL LUBE PUMPS
18	THRUST BEARING	38A	O-RING, SLEEVE (FRM-1 ONLY)*	65	MECHANICAL SEAL SEAT	91L	GREASE FITTING, GREASE LUBE PUMPS
19	BEARING HOUSING	38B	O-RING, SLEEVE (FRM-2 ONLY)*	71	ADAPTER	108	PIPE PLUG, DRAIN
22	LOCK NUT, BEARING	40	DEFLECTOR	71B	CAP SCREW, ADAPTER	153	CAP SCREW, BEARING COVER
22A	WASHER, BEARING LOCK NUT	45	VENT CAP	73	GASKET, CASING	153N	CAP SCREW, CASING
24	NUT, IMPELLER	46	KEY, COUPLING	73D	SEAL RING, THRUST BEARING COVER	211	RETAINING RING, SLEEVE
24A	LOCK WASHER, IMPELLER						