

THELCO CUTAWAY DRAWING OF WORTHINGTON® PUMP MODEL D-1012 FRAME 1A, 2, 3, 4, AND 5.

Thelco Corporation Englewood, CO. USA

www.thelco.com

PUMP SIZES: 2X1X10, 3X1-1/2X8, 3X1-1/2X10, 3X1-1/2X13, 3X2X6, 3X2X8, 3X2X10, 3X2X13, 4X3X5, 4X3X6, 4X3X8, 4X3X10, 4X3X13, 6X4X6, 6X4X8, 6X4X10, 6X4X11, 6X4X13, 8X6X11, 8X6X13, 8X6X15, 10X8X13, 10X8X15



© Any reproduction must include this copyright notice.

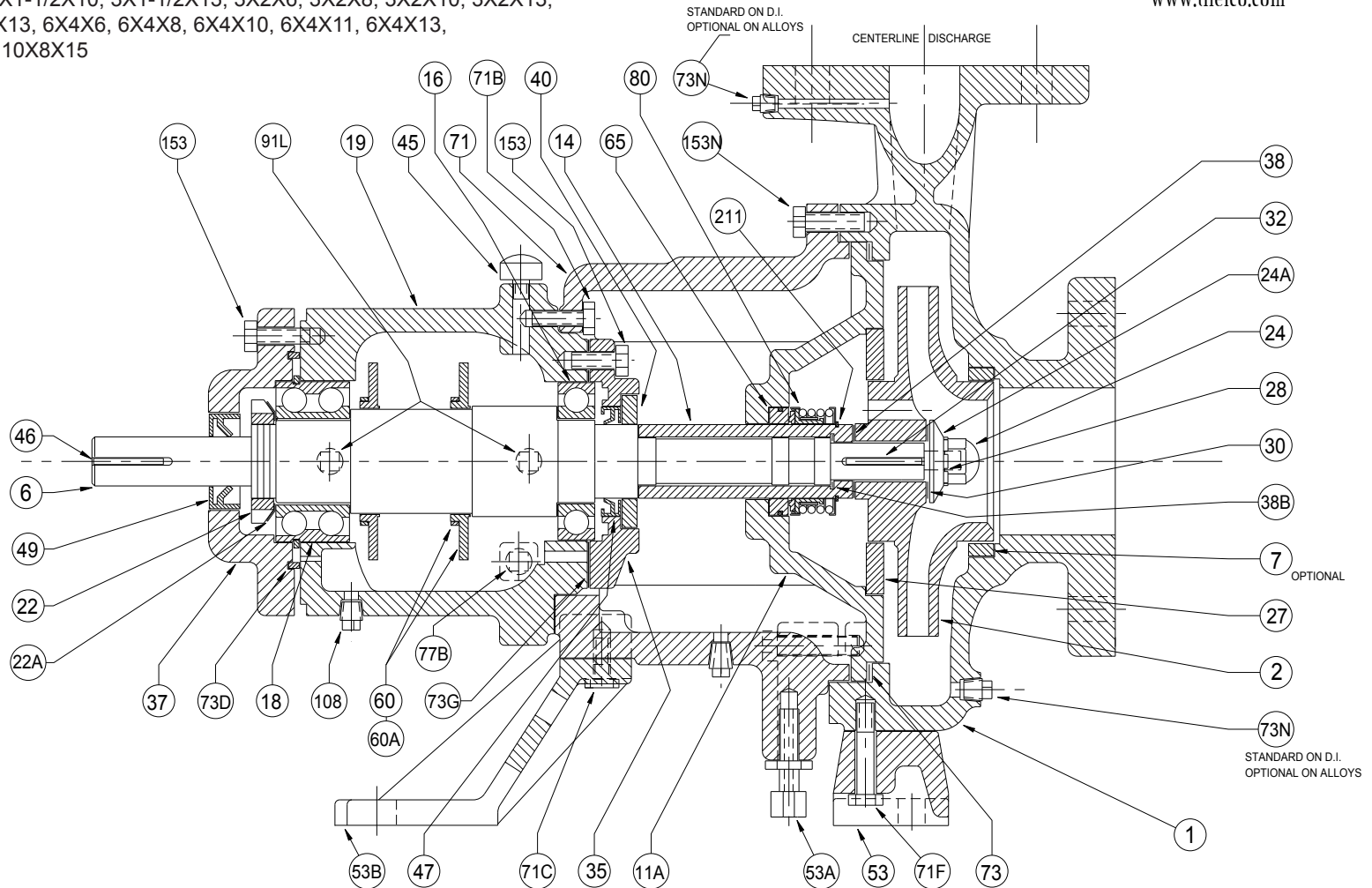
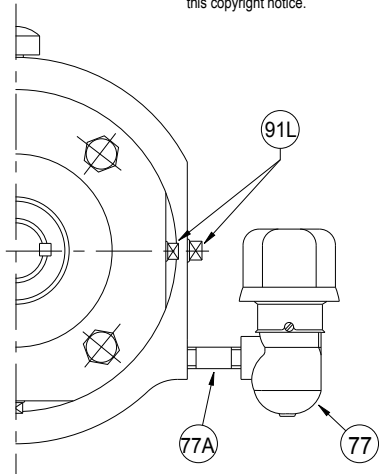

Note: Cut Shaft with Sleeve Version Shown.
Solid Shaft Version is Dimensionally Similar to Cut Shaft Including Sleeve.
Frm-1A Available in Cut Version Only.
*** These Two Parts are not Included with the Solid Shaft Version.

* Items contained in liquid end gasket kit.
** Items contained in frame end gasket kit

REFERENCE NUMBERS

WORTHINGTON® is a registered trademark of Ingersoll-Dresser Pump Company.
Thelco is not affiliated with WORTHINGTON® or Ingersoll-Dresser Pump Company

| | | | | | | | |
|-----|--------------------------------|-----|------------------------------|-----|--------------------------------|------|-------------------------------|
| 1 | CASING | 27 | RING, ADAPTER COVER | 53 | FOOT, CASING | 73G | GASKET, LINE BEARING COVER ** |
| 2 | IMPELLER | 28 | GASKET, IMPELLER NUT * | 53A | ADAPTER SUPPORT, INBOARD | 73N | PIPE PLUG, CASING |
| 6 | SHAFT (Shown Cut for a Sleeve) | 30 | GSKT, IMPELLER LOCK WASHER * | 53B | ADAPTER SUPPORT | 77 | CONSTANT LEVEL OILER |
| 7 | RING, CASING (OPTIONAL) | 32 | KEY, IMPELLER | 60 | FLINGER, OIL | 77A | NIPPLE, OILER |
| 11A | MECHANICAL SEAL COVER | 35 | COVER, LINE BEARING | 60A | COLLAR, OIL FLINGER | 77B | PIPE PLUG, GREASE LUBE PUMPS |
| 14 | SLEEVE, SHAFT *** | 37 | COVER, THRUST BEARING | 65 | MECHANICAL SEAL SEAT | 80 | MECHANICAL SEAL ROTOR |
| 16 | LINE BEARING | 38 | GASKET, SLEEVE (OUTER) * | 71 | ADAPTER | 91L | PIPE PLUG, OIL LUBE PUMPS |
| 18 | THRUST BEARING | 38B | GASKET, SLEEVE (INNER) * *** | 71B | CAP SCREW, ADAPTER | 91I | GREASE FTG, GREASE LUBE PUMPS |
| 19 | BEARING HOUSING | 40 | DEFLECTOR | 71C | CAP SCREW, ADAPTER FOOT | 108 | PIPE PLUG, DRAIN |
| 22 | LOCK NUT, BEARING | 45 | VENT CAP | 71F | CAP SCREW, CASING FOOT | 153 | CAP SCREW, BEARING COVER |
| 22A | WASHER, BRG LOCK NUT ** | 46 | KEY, COUPLING | 73 | GASKET, CASING * | 153N | CAP SCREW, CASING |
| 24 | NUT, IMPELLER | 47 | LIP SEAL, LINE BEARING ** | 73D | SEAL RING, THRUST BRG COVER ** | 211 | RETAINING RING, SLEEVE |
| 24A | LOCK WASHER, IMPELLER * | 49 | LIP SEAL, THRUST BEARING ** | | | | |