

THELCO CUTAWAY DRAWING OF WORTHINGTON® PUMP MODEL D-1011 FRAME 2, 3, 4, AND 5 COOLING CAP SERIES ANSI PUMPS
 PACKED BOX TYPE, SIZES; 2X1X10, 3X1-1/2X8, 3X1-1/2X10, 3X1-1/2X13, 3X2X8, 3X2X10, 3X2X13, 4X3X8, 4X3X10, 4X3X13
 6X4X8, 6X4X10, 6X4X11, 6X4X13, 8X6X11, 8X6X13, 8X6X15, 10X8X13, 10X8X15

Thelco Corporation Englewood, CO. USA

www.thelco.com



© Any reproduction must include this copyright notice.

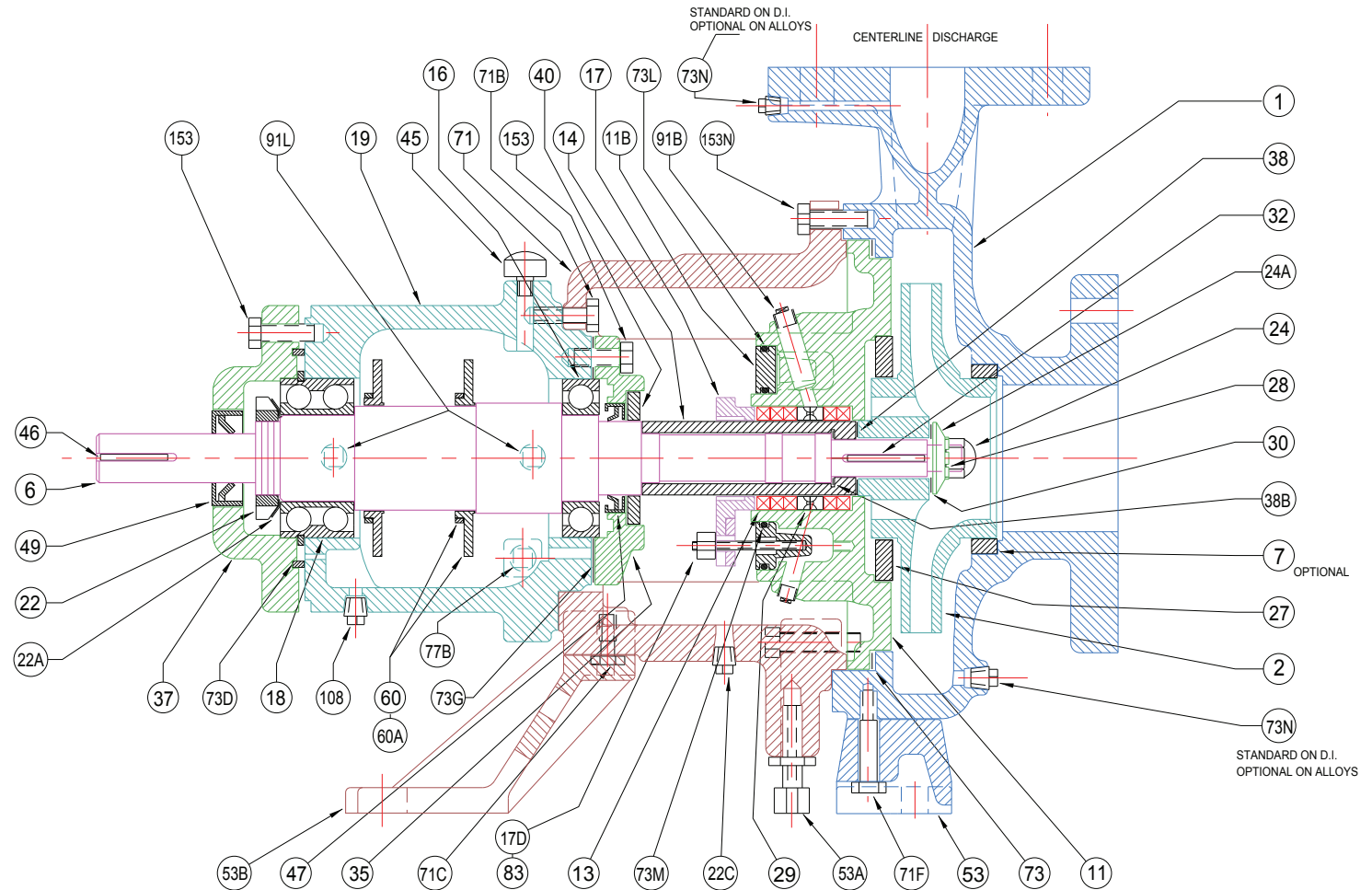
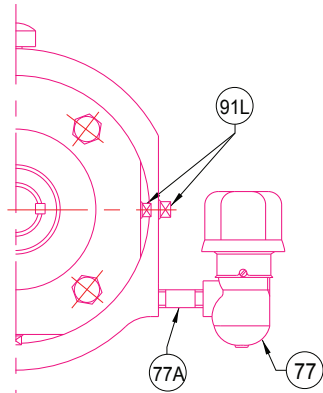

Note: Cut Shaft with Sleeve Version Shown.
 Solid Shaft Version is Dimensionally Similar to Cut Shaft Including Sleeve.
 Frm-1A Available in Cut Version Only.
 *** These Two Parts are not Included with the Solid Shaft Version.

* Items contained in liquid end gasket kit.

** Items contained in frame end gasket kit

REFERENCE NUMBERS

1	CASING	22C	PIPE PLUG	46	KEY, COUPLING	73G	GSKT, LINE BEARING COVER **
2	IMPELLER	24	NUT, IMPELLER	47	LIP SEAL, LINE BEARING **	73L	O-RING, COOLING CAP (OUTER)
6	SHAFT (Shown Cut for a Sleeve)	24A	LOCK WASHER, IMPELLER *	49	LIP SEAL, THRUST BEARING **	73M	O-RING, COOLING CAP (INNER)
7	RING, CASING (OPTIONAL)	27	RING, ADAPTER COVER	53	FOOT, CASING	73N	PIPE PLUG, CASING
11	STUFF BOX COVER	28	GASKET, IMPELLER NUT *	53A	ADAPTER SUPPORT, INBOARD	77	CONSTANT LEVEL OILER
11B	COOLING CAP	29	SEAL CAGE SET	53B	ADAPTER SUPPORT	77A	NIPPLE, OILER
13	PACKING SET	30	GSKT, IMPELLER LOCK WSHR *	60	FLINGER, OIL	77B	PIPE PLUG, GREASE LUBE PUMPS
14	SLEEVE, SHAFT ***	32	KEY, IMPELLER	60A	COLLAR, OIL FLINGER	83	STUD, PACKING GLAND
16	LINE BEARING	35	COVER, LINE BEARING	71	ADAPTER	91B	PIPE PLUG, STUFF BOX
17	GLAND, PACKING	37	COVER, THRUST BEARING	71B	CAP SCREW, ADAPTER	91L	PIPE PLUG, OIL LUBE PUMPS
17D	NUT, GLAND STUD	38	GASKET, SLEEVE (OUTER) *	71C	CAP SCREW, ADAPTER FOOT	91L	GREASE FTG, GREASE LUBE PUMPS
18	THRUST BEARING	38B	GASKET, SLEEVE (INNER) * ***	71F	CAP SCREW, CASING FOOT	108	PIPE PLUG, DRAIN
19	BEARING HOUSING	40	DEFLECTOR	73	GASKET, CASING *	153	CAP SCREW, BEARING COVER
22	LOCK NUT, BEARING	45	VENT CAP	73D	SEAL RING, THRUST BRG COVER **	153N	CAP SCREW, CASING
22A	WASHER, BRG LOCK NUT **						

WORTHINGTON® is a registered trademark of Ingersoll-Dresser Pump Company.
 Thelco is not affiliated with WORTHINGTON® or Ingersoll-Dresser Pump Company

Nov 2008